

**\*\*VIP\*\*** - If you purchased your MK95A Valve, or any stem repair component for this valve after 9/17/2018 - please see assembly instruction change on page 2, top-right, section 3.

 <p>STERIFLOW a division of Jordan Valve</p> <p>3170 Wasson Road • Cincinnati, OH 45209 USA Phone 513-533-5600 • Fax 513-871-0105 steriflow@richardsind.com • www.steriflowvalve.com</p>	<b>I &amp; M Mark 95LL Series 1-1/2" to 3" Valves</b>
	<i>Installation &amp; Maintenance Instructions for MK95LL Sanitary Back Pressure Regulators</i>

**Warning:** Steriflow Sanitary Pressure Regulators must only be used, installed and repaired in accordance with these Installation & Maintenance Instructions. Observe all applicable public and company codes and regulations. In the event of leakage or other malfunction, call a qualified service person; continued operation may cause system failure or a general hazard. Before servicing any valve, disconnect, shut off, or bypass all pressurized fluid. Before disassembling a valve, be sure to release all spring tension.

**Please read these instructions carefully!**

Your Steriflow product will provide you with long, trouble free service if it is correctly installed and maintained. Spending a few minutes now reading these instructions can save hours of trouble and downtime later. When making repairs, use only genuine Jordan Valve parts, available for immediate shipment from the factory.

5. Use caution in tightening commercial sanitary fittings. Over-tightening can cause the gasket to extrude into the flow passage.
6. If possible, install a relief valve downstream from the regulator. Set at about 30% above the control point of the regulator.
7. Operate the regulator within its pressure and temperature rating as stamped on the valve nameplate.

**Ideal Installation**

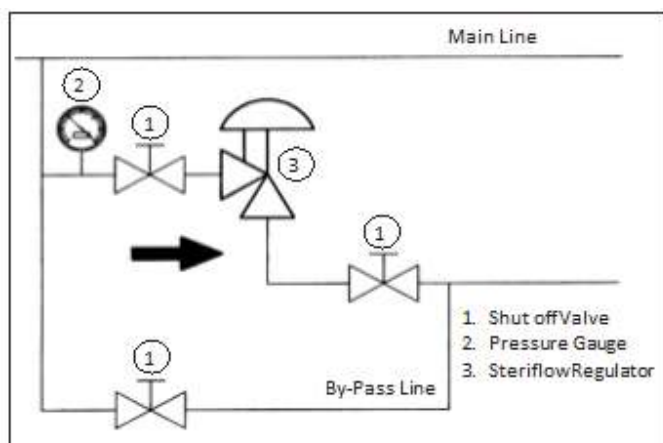

1. The valve is designed for sanitary service and it is assumed that it will be installed into a clean system. Under these conditions, special considerations to protect the valve such as providing line strainers at the valve inlet are not necessary.
2. The regulator is to be installed with the inlet horizontal and the outlet pointed down. This will provide the best drainage inside the valve. These restrictions apply only for drainage considerations; the valve will function in any position. Contact factory for other possible orientations.
3. Steam regulators are best located at the highest point in the piping with the take-off out of the top of the steam header. This will minimize the possibility of water in the regulator.
4. For best control, 3' 0" straight sections of pipe should be installed on either side of the regulator.

**Start Up**

1. Slowly open the inlet shutoff valve and slowly turn the adjusting screw until the desired inlet pressure is shown on the inlet pressure gauge, without discharging fluid.
2. To change the controlled pressure, turn the adjusting block (28) with handles (43) clockwise to increase the pressure, or counterclockwise to decrease the pressure. Do not adjust while the lift system is in use!
3. See section on cleaning cycle for lift cam instructions and usage. (see section on Clean-In-Place/ Steam-In-Place.)

**Maintenance**

Caution: Make certain that there is no pressure in the valve before loosening any fittings or joints. The following steps are recommended:

1. Close the inlet shutoff valve.
2. Turn the adjusting block (28) counterclockwise until there is no pressure on the spring, allowing any trapped pressure to release downstream.
3. Allow pressure to bleed off through the downstream piping. Do not attempt to reverse the flow through the valve by bleeding pressure from the upstream side of the valve.
4. When the pressure gauges indicate that all pressure has been removed from the system, close the outlet shutoff valve. The valve may be removed from the line and serviced.

Note: refer to the drawing at the end of this document for description and proper orientation of parts.

**PROTECT VALVES WITH LINESTRAINERS**

---

## Clean-In-Place

---

To open the valve to open for cleaning, unscrew one of the handles (43) from the adjusting block (28) and screw it into the cam (30). Pull the handle (43) down and towards you without rotating the adjusting block (28). Secure the cam in the open position (see detail on back page) with the 1/4" self locking pin (39). This will unseat the plug and allow cleaning media to freely flow through the valve. When cleaning is complete, remove the 1/4" self locking pin (39) and raise the handle (43) straight up without rotating the adjusting block (28). Remove handle (43) from cam (30) and screw it back into the adjusting block (28).

Note: when the cam lever is in the down position the valve will not regulate! Do not rotate the adjusting block when the lever is in the down position.

---

## Disassembling the Valve

---

1. Follow the instructions under the "Maintenance" section to remove the valve from line.
2. Turn the adjusting block (28) counterclockwise to remove the load from the range spring.
3. Remove the cam (30) by pulling out the 3/8" self locking pin (38). Lift the adjusting block (28) off and set aside. Remove HHCS (15) and set aside.
4. Remove the spring housing (42), spring guide (33), bearings (35)(36), and spring (9). Set parts aside.
5. Remove the cam connector (41) by removing roll pin (40). Remove cotter pin (25), flat washer (24), and two Belleville washers (23).
6. Remove set screw (27) unscrew bell (22). Lift bell (22) and stem (19). Unscrew stem connector (26) from valve stem (6). Remove lockwasher (10), cylinder (17), spacer (12), and gland bushing (14).
7. Remove adapter plate (2), upper diaphragm plate (4), diaphragm (11). Remove and discard o-ring (8), remove lower diaphragm plate (5), remove and discard o-ring (7).

CAUTION: If the valve is equipped with a metal diaphragm, the edges are very sharp. Exercise caution to avoid lacerations.

---

## Preparing Valve For Assembly

---

All parts should be cleaned and examined. Damaged parts should be replaced.

Note: For all assembly lubrication requirements, follow instructions for soft seated valves that meet the following conditions:

- If you are working on a valve that was purchased after 9/17/2018.
- If you are installing a repair kit for a valve that was purchased after 9/17/2018, and a part number in that repair kit has a model suffix of -SLFLK, -SFLK, or -SLK.

New Loctite Instructions for valves that meet the above conditions:

- Loctite is no longer required for wetted stem component assembly. It can still be used, but its use will make future stem disassembly more difficult.

For valves or parts that don't meet the above conditions use the following instructions:

For valves or parts that don't meet the above conditions use the following instructions:

Clean threads on the stem and on retainer with Loctite primer 7649. Follow Loctite's instructions for primer and sealant. Install new soft seat onto retainer (or onto stem when applicable on low flow versions). Apply Loctite Sealant 2046 to threads and thread the retainer onto the stem. Tighten until the screw threads run out. Allow to cure.

---

## Assembling the Valve

---

### 1-1/2"-3"

1. Lubricate o-ring and install into the groove in the body (1) (not required with an elastomer diaphragm).
2. Lubricate o-ring (7) and install into the groove in the lower diaphragm plate (5).
3. Install lower diaphragm plate (5) onto stem (6)
4. Install o-ring (8) onto lower diaphragm plate (5). Install diaphragm (11) onto stem (6). Install upper diaphragm plate (4) onto stem.
5. Install gland bushing (14) into guide bushing (18).
6. Install stem (6) into the body (1). Center diaphragm onto body. [When using the ultra-thin Jorlon diaphragm, install Gylon gasket centered over diaphragm.]
7. Install adapter (2) onto the body (1). The adapter (2) should engage the pilot diameter on the body (1) and the drain slot should be over the inlet.
8. Install spacer (12) and cylinder (17) on to the stem (6).
9. Install lock-washer (10) on to stem (not required with an elastomer diaphragm).
10. Install stem connector (26) on to stem and tighten. If elastomer diaphragm, tighten only 1/4 turn and apply Loctite No. 290 to the threads to lock the joint.
11. Install lift lever stem (19) into bell (22). Screw bell (22) on to stem connector (26). Secure bell (22) with CPSS (27).

12. Install two Belleville washers (23) and one flat washer (24) on to lift lever stem (19). Secure with cotter pin (25).
13. Install thrust washer (36) and needle bearing (35) on to adjusting screw cap (21).
14. Align slots in spring guide (33) with spring housing guides (32) and insert assembly into spring housing (42). Place spring (9) into cylinder (17).
15. Install spring housing assembly (42) over spring (9) and on to valve. Secure spring housing (42) with twelve HHCS (15). Cross tighten to 200 in-lbs.
16. Install cam connector (41) on to lift lever stem (19) and secure with roll pin (40).
17. If lift lever plate (29) is worn, remove screws (31) and flip over, then reinstall screws.
18. Place adjusting block over cam connector (41) and adjusting screw cap (21).
19. Install cam (30) in the orientation shown on the "CLOSED POSITION" detail view with cam connector (41) inside center slot of cam (30) and secure with 3/8" self locking pin (38).
20. Screw the two handles (43) into the adjusting block (28). Turn the adjusting block clockwise to establish a set point to seat the plug (6). Unscrew one of the handles (43) from the adjusting block(28) and screw it into the cam (30). Pull the handle (43) down and toward you, then secure with the 1/4" self locking pin (39). Check to make sure the plug (6) has lifted and is no longer seated. Reverse the process to reseat the plug and replace the handle used for the cam back into the adjusting block.

---

## Ordering Spare Parts

---

Use only genuine Steriflow Valve parts to keep your valve in good working order. So that we can supply the parts, which were designed for your valve, we must know exactly which product you are using. The only guarantee to getting the correct replacement parts is to provide your Steriflow Representative with the valve serial number. This number is located on the valve identification tag. If the serial number is not available, the parts needed for your valve might be determined using the following information: Model Number, Valve Body Size, Seat Material and Cv Rating, Spring Range and Set Point, Trim Material, Part Name - Number and Quantity.

NOTE: Any parts ordered without a valve serial number that are found to be incorrect are subject to up to a minimum 25% restock charge when returned.

---

## Troubleshooting

---

### **If You Experience Erratic Control:**

- Regulator may be oversized. Oversizing causes cycling, hunting, and reduces the rangeability of the valve – make certain that your valve has been correctly sized for your application conditions
- Valve seat may be defective - replace stem and/or body.
- Valve plug may not be moving freely – inspect the cylinder and spring housing.

### **Upstream Pressure Build-up or Inability to Maintain Regulated Pressure.**

- Inspect for jamming between cylinder and spring housing.
- Diaphragm may have failed - replace if necessary.
- Piping may be blocked or undersized.
- Range spring may be set too high or may be broken - inspect and reset or replace as necessary.
- The valve may be undersized for required flow - make certain that the valve has been sized correctly.

## Illustration and Parts List (1-1/2" - 3")

**Closed Position**

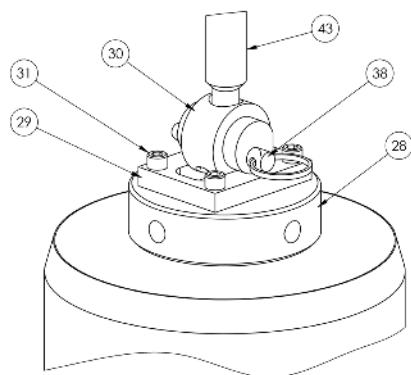

**Open Position**

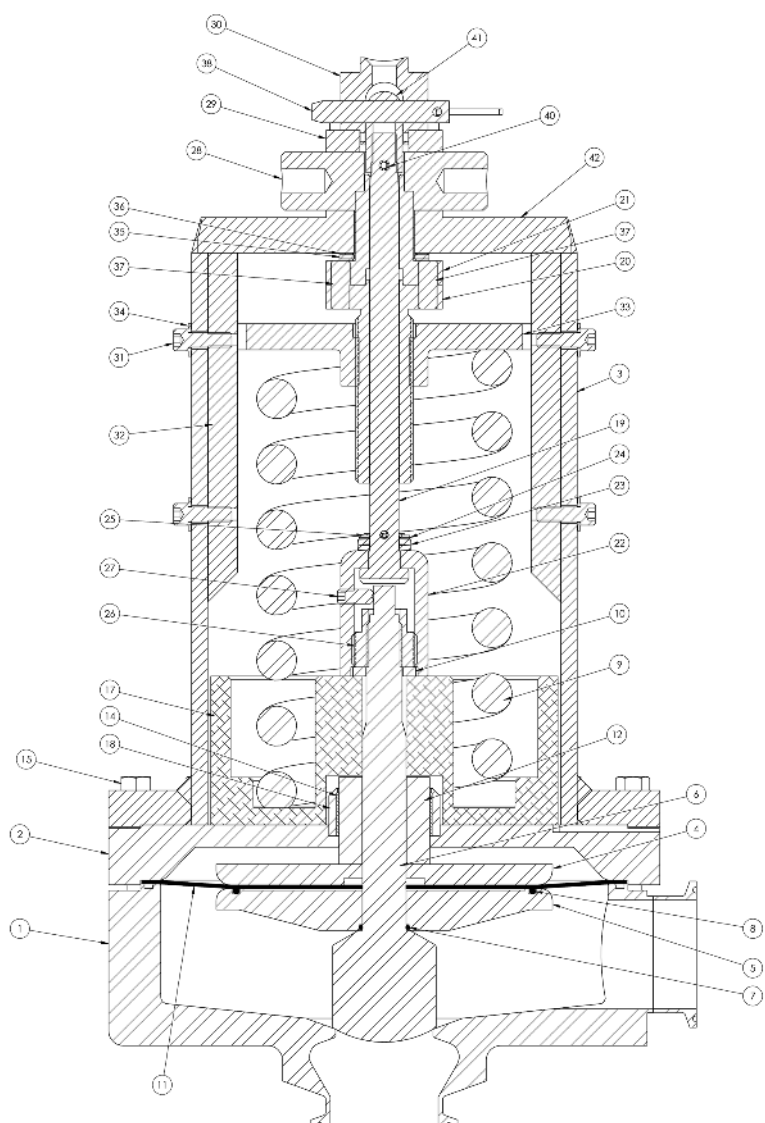
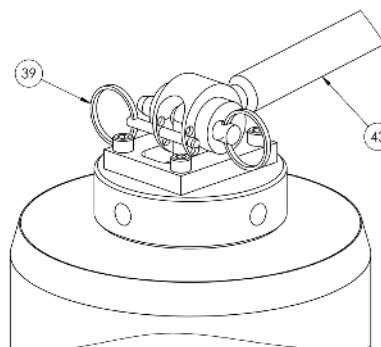

Item No.	Accessories	Qty.
1	Body	1
2	Adapter Plate	1
3	Spring Housing	1
4	Upper Diaphragm Plate	1
5	Lower Diaphragm Plate	1
6	Stem/Plug	1
7	O-Ring #018	1
8	O-Ring #159	1
9	Range Spring	1
10	Lockwasher 5/8"	1
11	Diaphragm	1
12	Spacer	1
13	Support Washer (not shown)	2
14	Gland Bushing	1
15	HHCS 5/16-18 X 2"	12
16	Washer 3/8"	1
17	Cylinder	1
18	Guide Bushing	1
19	Lift Lever Stem	1
20	Adjusting Screw	1
21	Adjusting Screw Cap	1
22	Bell	1
23	B'ville Washer	2
24	Flat Washer	1
25	Cotter Pin	1
26	Stem Connector	1
27	Cup Point Set Screw	1
28	Adjusting Block	1
29	Lift Lever Plate	1
30	Cam	1
31	SHCS 1/4-20 X 3/4"	8
32	Spring Housing Guide	2
33	Spring Seat	1
34	Thread Seal	4
35	Needle Bearing	1
36	Thrust Washer	2
37	Pin-Knurled End	2
38	Self-Lock Pin 3/8"	1
39	Self-Lock Pin 3/16"	1
40	Roll Pin	1
41	Cam Connector	1
42	Spring Housing	1
43	Lift Lever Handle (removable)	2