

Warning: Steriflow Valve Pressure Regulators must only be used, installed and repaired in accordance with these Installation & Maintenance Instructions. Observe all applicable public and company codes and regulations. In the event of leakage or other malfunction, call a qualified service person; continued operation may cause system failure or a general hazard. Before servicing any valve, disconnect, shut off, or bypass all pressurized fluid. Before disassembling a valve, be sure to release all spring tension.

Please read these instructions carefully!

Your Steriflow Valve product will provide you with long, trouble-free service if it is correctly installed and maintained. Spending a few minutes now reading these instructions can save hours of trouble and downtime later.

When making repairs, use only genuine Steriflow Valve parts, available for immediate shipment from the factory.

Ideal Installation

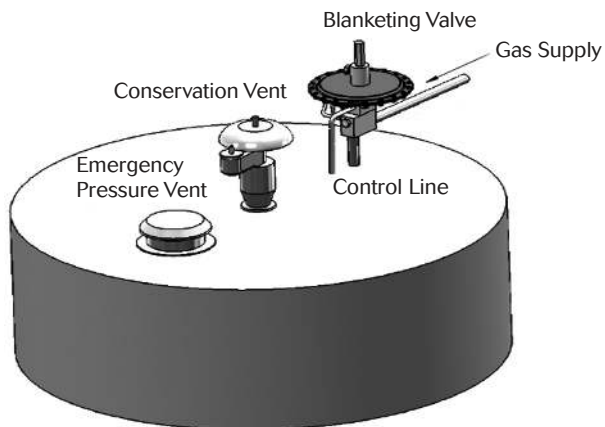

- To protect the valve from grit, scale, thread chips and other foreign matter, ALL pipelines and piping components should be blown out and thoroughly cleaned before the installation process begins.
- Shutoff valves, pressure gauges and by-pass piping are optional, and if installed should be in accordance with all applicable codes, standards, and practices. They are recommended to provide easier adjustment, operation, and testing.
- The flow arrow on the valve body must be pointed in the direction of flow. Ideally, the valve should be installed in the highest horizontal line of piping.
- Install the relief valve on the tank. Set above the control point of the valve but below the maximum safety limit for the tank.

- It is strongly recommended that the installer read and be thoroughly familiar with API 2000, Standard Information for Tank Blanketing Regulator Selection before installing and attempting to operate this product.

Control Line

A control line must be installed as follows:

- Connect one end of a 1/2" NPS pipe to the fitting on the bottom of the main valve actuator.
- Connect the other end to an appropriate fitting on the tank.
- DO NOT locate the control line tap in any location where turbulence or abnormal velocities may occur.
- The control line should be sloped away from the valve.
- Install a pressure gauge to measure pressure in the tank itself, not in the outlet piping or the control line to aid in setting the valve.

Control line should slope downward toward the tank to prevent condensation buildup.

- Make the control line as short and straight as possible.
- Connect the control line to the point where the pressure is to be controlled.
- Increase 1 pipe size for every 10 feet of control line, with setpoints less than 5" w.c. (0,012 bar).

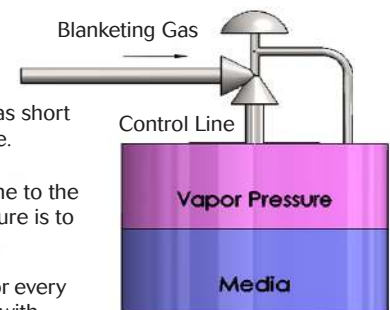

Control Line Piping Recommendation

- Keep the regulator as close to the tank as possible and as high as possible.
- Minimize the length of the downstream pipe coming from the valve.

Mark 908 Series Tank Blanketing Valve

- NEVER reduce the pipe size on the valve outlet to the tank. This line must always be as large as the valve size, or one pipe size larger to assure it does not act as a restriction.
- Any downstream isolation valve after the regulator must be a full port type. The isolation valve cannot act as a restriction.
- The sensing line must be a minimum of 3/8" tube.
- A sensing line isolation valve is recommended. Again, must be full ported.
- Slope the sensing line to the sensing port on the tank.
- Keep the sensing line as short and straight as possible.
- For each 10 feet of sensing line, increase the tube by 1/8". (Especially important on the blanket pressures of less than 5 inches of water column).
- Keep the sensing port on the tank as far removed as possible from the downstream pipe outlet going into the tank.

Start-Up

With the inlet, and bypass shutoff valves closed, and no pressure in the downstream line:

1. Slowly open the inlet valve just enough to start flow through the valve. Observe the tank pressure gauge. Increase the downstream pressure slowly by gradually opening the inlet valve.
2. Do not fully open the inlet valve until you are sure that the regulator has control of the system. Usually, the handwheel on the inlet valve will turn freely when this is achieved.
3. To change the controlled pressure, adjust the set screw (25), and secure with the jam nut (26), and the closing cap (12).

Trouble Shooting

The first step in troubleshooting a piloted pressure regulator is to classify the action of the controlled pressure into one of the following categories:

- A. Under Pressure: Controlled pressure too low; not enough flow or no flow through valve.
- B. Over Pressure: Valve will not close or controlled pressure increases after valve closes.
- C. Pressure Fluctuates: Controlled pressure rises and falls, will not settle out under low loads.

The next step is to determine what could cause the trouble. The third step is to locate and remedy the cause by the process of elimination. Make no assumptions and check the easy ones first. The guide below lists the controlled pressure action, common causes and procedure for checking each cause.

Controlled pressure action UNDER PRESSURE:

- Valve undersized for application. Check capacity required and valve capacity. As described in API-2000.
- Line strainer screen clogged. Blow down strainers or visually check that they are clear.
- Incorrect setting on range spring. Vary the setting and check response.
- Main valve diaphragm or balance diaphragm ruptured. See section on valve maintenance.
- Malfunction of other piping components. Check for leaking safety valves, inadvertently opened or closed valves.

Controlled pressure action OVER PRESSURE:

- Incorrect setting on range spring. Vary the setting and check response.
- Main valve seats leaking. Close inlet shut-off valve, allow downstream pressure to bleed off, close outlet valve and remove loading pressure tubing. Back out adjusting screw on valve until free. Crack open inlet shut-off valve - if the fluid issues from the main valve port, the main valve seats are leaking.
- By-pass shut-off leaking. During period of leakage close outlet shut-off valve, observe downstream pressure gauge
- Under certain circumstances, the vent valve may be open when the tank is not being filled. This may not be caused by an inability to control or seat leakage. The tank may be "outbreathing" due to increases in the temperature of the gas or contents inside the tank.

Controlled Pressure Fluctuates:

- Valve oversized. Check capacity required and valve capacity per API 2000.

Main Valve

Note: All work to the main valve can be accomplished in-line. The only reason to remove the valve is if the location makes it too difficult to work on the regulator.

Diaphragm Replacement

Parts Required for this operation: seal washer (27), diaphragm (11), two actuator case gaskets (21), and closing cap o-ring (45).

1. Remove closing cap (12). Remove and discard closing cap o-ring (45).
2. Mark position of adjusting screw (25) where it meets the jam nut (26).
3. Slightly loosen the jam nut (26) and remove the adjusting screw (25), leaving the jam nut in position.
4. Remove actuator case bolts and washers (23)(35) (36). Remove upper actuator case assembly (16).
5. Remove the upper spring guide (20) and range spring (38). Remove the diaphragm assembly (15).
6. Remove and discard the upper and lower actuator case gaskets (21).
7. Remove the diaphragm retaining nut (22) from the diaphragm assembly. Remove the upper diaphragm plate (15), diaphragm (11), lower diaphragm plate (14), and discard the seal washer (27).

If replacing only the diaphragm, reassemble in reverse order using new replacement parts. If replacing internal seals or other parts, continue to section below.

Internal Seal Replacement

Parts Required for this operation: Steriflow Valve seal kit consisting of the following parts: teflon sheet gasket (13), pilot upper cage o-ring (32), two pilot body inner o-rings (31), pilot plug o-ring (29), rolling diaphragm-pilot (17), pilot body/main body o-ring (34), main piston o-ring (5), main plug o-ring (33), and four threadseal washers (43).

1. Remove the four HHCS (28), discard the threadseal washers (43), and lift off the actuator lower case (9).
2. Remove and discard the flat teflon gasket (13). Remove and discard the pilot upper cage o-ring (32).
3. Firmly grasp the stem of the pilot plug (4) and pull the pilot upper cage (8) out of the pilot body (2). Remove the pilot plug return spring (40) and the pilot lower cage (7) from the pilot body (2).
4. Remove the pilot plug assembly (4)(17)(30) from the pilot upper cage.
5. Referring to the tubing connection inset, disconnect the tubing at points (A) and (B).
6. Remove and discard the two pilot body inner o-rings (31).

1. Separate the main body (1) from the pilot body (2). Remove and discard the pilot body / main body o-ring (34).
2. Remove the main plug assembly (3), main plug return spring (39), and the spring spacer (18). Remove and discard the main piston o-ring (5) from the main piston (3).
3. Refer to section "B". Remove screw (42) and lock-washer (41) from the main piston. Remove the main plug (6) and replace the main plug o-ring (33). Replace main plug (6), lockwasher (41), and screw (42). Replace the main piston o-ring (5).
10. Place the plug assembly back on its seat in the main body. Place the spacer (18) and the return spring (39) into the main plug assembly.
11. Replace the pilot body / main body o-ring (34). Place the pilot body (2) back onto the main body (1). Reconnect the tubing at points (A) and (B).
12. Retrieve the pilot plug assembly (4)(17)(30) from step 4 above. Separate the components and discard the pilot rolling diaphragm (17).
13. Rebuild the pilot plug assembly using a new rolling diaphragm from the repair kit. Make sure the "bead" on the rolling diaphragm faces the pilot piston (30) as shown in Detail 'A' on the parts diagram. Install the new the pilot plug o-ring (29) onto the pilot plug (4).
14. Install the two new pilot body inner o-rings (31).
15. Place the pilot lower cage back into the pilot body bore. Place the pilot return spring (40) into the pilot lower cage.
16. Place the pilot plug assembly into the pilot lower cage, making sure the "bead" on the pilot rolling diaphragm goes into the groove on the top of the pilot lower cage (7).
17. Install the pilot upper cage (8) into the pilot body (2), making sure the stem of the pilot plug (4) is visible through the top of the pilot upper cage. Install a new pilot upper cage o-ring (32).
18. Replace the Teflon gasket (13), and place the lower case (9) onto the top of the teflon gasket. Secure the lower case to the pilot body and the main body with four HHCS (28) and four new threadseal washers (43).

Return to Section I above and reassemble in reverse order

MARK 908 PARTS LIST

The following parts list includes complete part numbers for components of the Mark 908 that are generally replaceable in the field, and are most commonly used. Key numbers correspond to those in Figures 3 and 4. Include the serial number of your actuator in all correspondence regarding replacement parts.

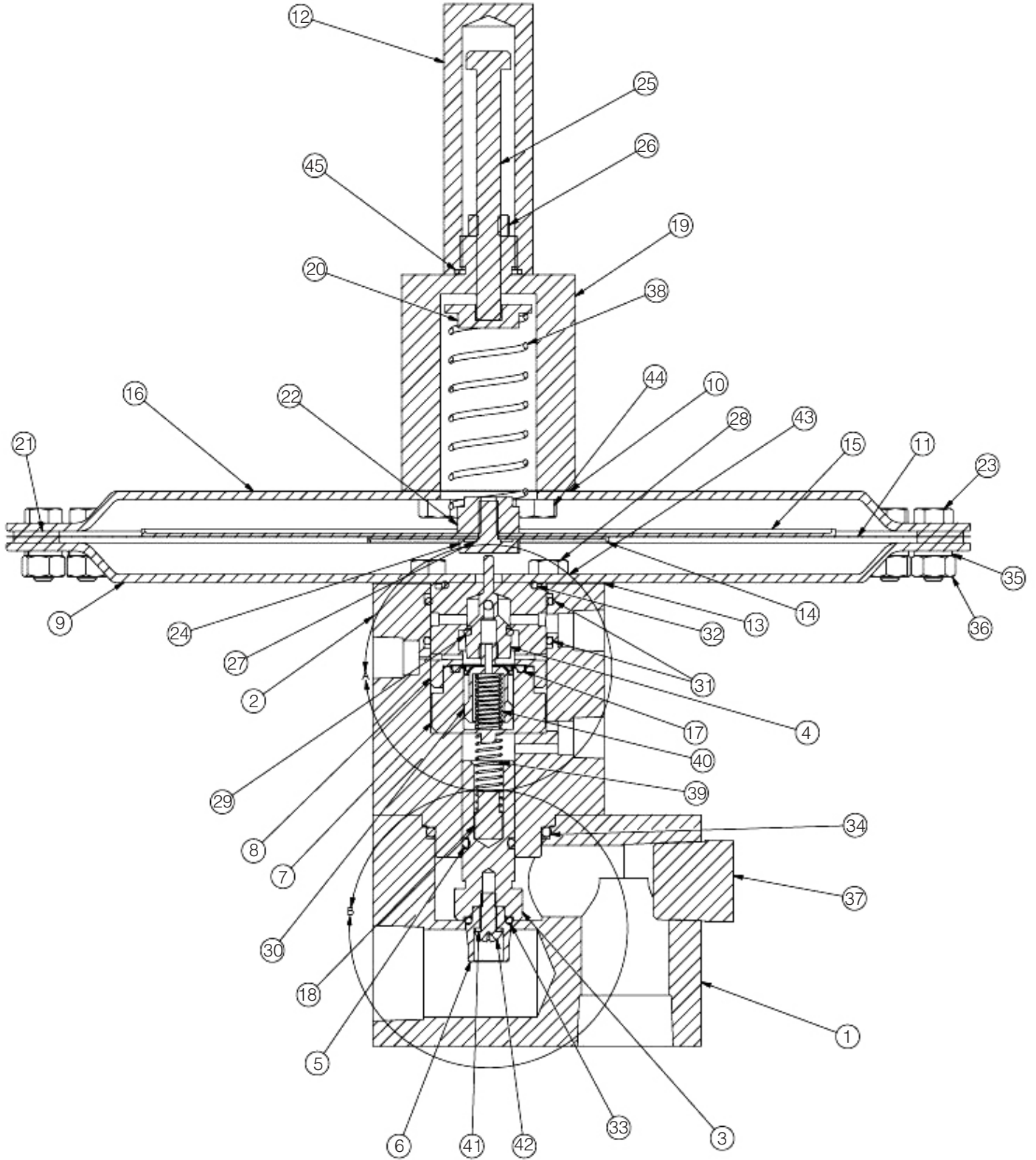

Mark 908 Series Tank Blanketing Valve

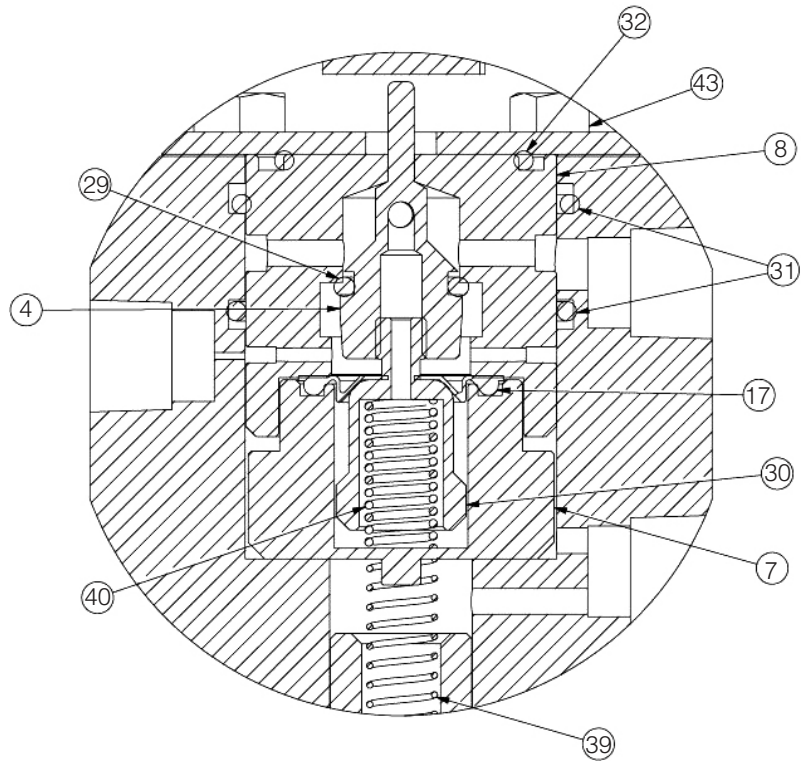

Detail "A"

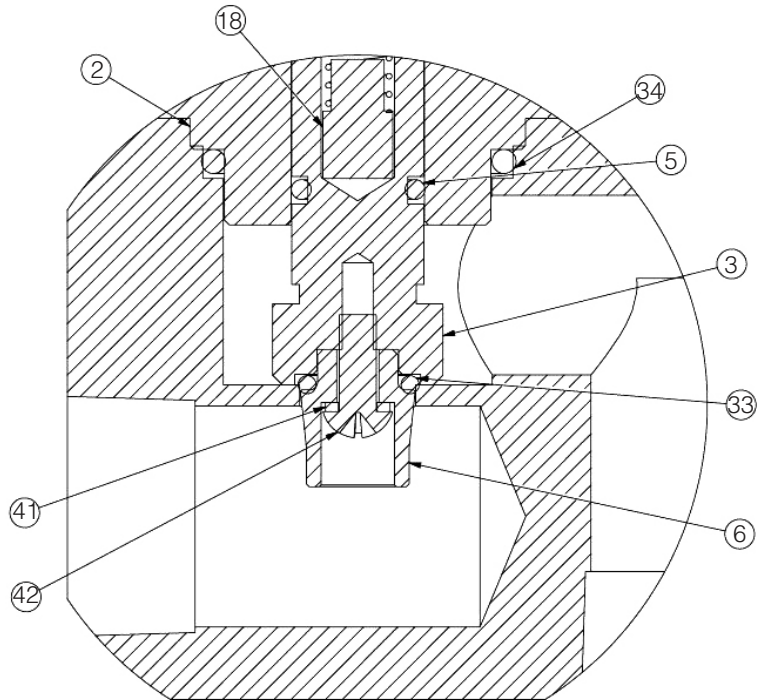

Detail "B"

Mark 908 Series Tank Blanketing Valve

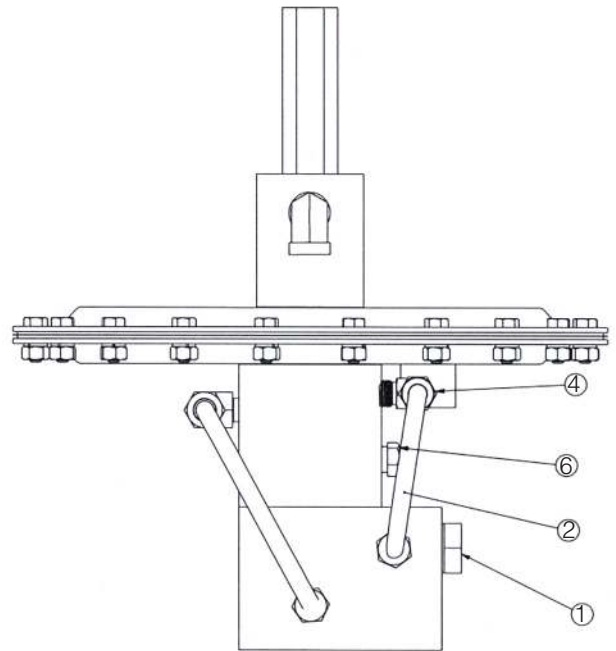
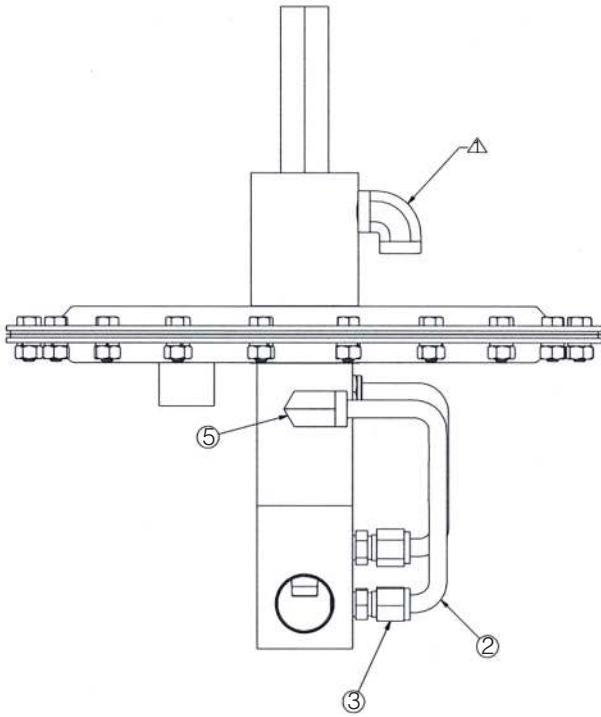

MK908 Accessories and Tubing Assembly			
Item #	Part Number	Description	Qty.
1	26904-*	Pipe Plug 3/4" MNPT	1
2	T038-035-68	SST Tubing	12 in
3	79839-*	Tubing Connector	2
4	82975-*	Elbow Tube (MNPT)	2
5	64155-*	Street Elbow 1/4" M-F	1
6	67541-*	Pipe Plug 1/4" MNPT	2
7	27528-*	Vent-Nylon Elbow	1

NOTES:

1 Install with open end down as shown

Mark 908 Series Tank Blanketing Valve

MK908 SEALS INSTALLATION GUIDE			
1" MK908 Cv 1-2 KEY PART#	PLACEMENT	MAPICS DESCRIPTION	QTY
24265-*	32 PILOT UPPER CAGE	O-RING B-N #122 1.318 X 1.112 X .103	1
26579-*	17 PILOT DIAPHRAGM	DIAPHRAGM BALANCE 1" MK908	1
82027-*	29 PILOT PLUG	O-RING B-N #110 9/16 X 3/8 X 3/32	1
82262-*	5 MAIN PISTON	O-RING B-N #112 11/16 X 1/2 X 3/32	1
86351-*	31 PILOT INNER BODY	O-RING B-N #128 1-11/16 X 1-1/2 X 3/32	2
86356-*	45 CLOSING CAP	O-RING B-N #018 7/8 X 3/4 X 1/16	1
8667-*	33 MAIN PLUG	O-RING B-N #111 5/8 X 7/16 X 3/32	1
92446-*	34 PILOT BODY/ MAIN BODY	O-RING B-N #220 1-5/8 X 1-3/8 X 1/8	1

MK908 SEALS INSTALLATION GUIDE			
1" MK908 Cv 4 KEY PART#	PLACEMENT	MAPICS DESCRIPTION	QTY
24265-*	32 PILOT UPPER CAGE	O-RING B-N #122 1.318 X 1.112 X .103	1
26579-*	17 PILOT DIAPHRAGM	DIAPHRAGM BALANCE 1" MK908	1
82027-*	29 PILOT PLUG	O-RING B-N #110 9/16 X 3/8 X 3/32	1
92926-*	5 MAIN PISTON	O-RING B-N #113 3/4 X 9/16 X 3/32	1
86351-*	31 PILOT INNER BODY	O-RING B-N #128 1-11/16 X 1-1/2 X 3/32	2
86356-*	45 CLOSING CAP	O-RING B-N #018 7/8 X 3/4 X 1/16	1
82262-*	33 MAIN PLUG	O-RING B-N #112 11/16 X 1/2 X 3/32	1
92446-*	34 PILOT BODY/ MAIN BODY	O-RING B-N #220 1-5/8 X 1-3/8 X 1/8	1

MK908 SEALS INSTALLATION GUIDE			
1" MK908 Cv 7.5 KEY PART#	PLACEMENT	MAPICS DESCRIPTION	QTY
24265-*	32 PILOT UPPER CAGE	O-RING B-N #122 1.318 X 1.112 X .103	1
26579-*	17 PILOT DIAPHRAGM	DIAPHRAGM BALANCE 1" MK908	1
82027-*	29 PILOT PLUG	O-RING B-N #110 9/16 X 3/8 X 3/32	1
86353-*	5 MAIN PISTON	O-RING B-N #115 11/16 X 7/8 X 3/32	1
86351-*	31 PILOT INNER BODY	O-RING B-N #128 1-11/16 X 1-1/2 X 3/32	2
86356-*	45 CLOSING CAP	O-RING B-N #018 7/8 X 3/4 X 1/16	1
67429-*	33 MAIN PLUG	O-RING B-N #114 5/8 X 13/16 X 3/32	1
92446-*	34 PILOT BODY/ MAIN BODY	O-RING B-N #220 1-5/8 X 1-3/8 X 1/8	1

MK908 SEALS INSTALLATION GUIDE			
1" MK908 Cv 10 KEY PART#	PLACEMENT	MAPICS DESCRIPTION	QTY
24265-*	32 PILOT UPPER CAGE	O-RING B-N #122 1.318 X 1.112 X .103	1
26579-*	17 PILOT DIAPHRAGM	DIAPHRAGM BALANCE 1" MK908	1
82027-*	29 PILOT PLUG	O-RING B-N #110 9/16 X 3/8 X 3/32	1
8245-*	5 MAIN PISTON	O-RING B-N #116 15/16 X 3/4 X 3/32	1
86351-*	31 PILOT INNER BODY	O-RING B-N #128 1-11/16 X 1-1/2 X 3/32	2
86356-*	45 CLOSING CAP	O-RING B-N #018 7/8 X 3/4 X 1/16	1
86353-*	33 MAIN PLUG	O-RING B-N #115 11/16 X 7/8 X 3/32	1
92446-*	34 PILOT BODY/ MAIN BODY	O-RING B-N #220 1-5/8 X 1-3/8 X 1/8	1

Mark 908 Series Tank Blanketing Valve

Key	Part Name	Description	Qty.
1	VARIABLES	MAIN BODY 1" FNPT	1
2	VARIABLES	PILOT BODY	1
3	VARIABLES	MAIN PISTON	1
4	26588-*	PILOT PLUG	1
5	SEE BELOW	MAIN PISTON O-RING PLUG SEAL 2-112	1
6*	SEE BELOW	MAIN PLUG	1
7	26576-*	PILOT LOWER CAGE	1
8	26580-*	PILOT UPPER CAGE	1
9	26678-*	ACTUATOR CASE (LOWER)	1
10	26680-*	SPRING HOUSING GASKET	1
11	26565-*	DIAPHRAM PFA	1
12	26568-*	CLOSING CAP	1
13	26683-*	GASKET	1
14	26566-*	LOWER DIAPH PLATE MK908 316SS	1
15	26567-*	UPPER DIAPH PLATE MK908 316SS	1
16	26564-*	ACTUATOR CASE (UPPER)	1
17	26579-*	ROLLING DIAPHRAGM- PILOT	1
18	VARIABLES	SPACER	1
19	26573-*	SPRING HOUSING	1
20	VARIABLES	UPPER SPRING GUIDE	1
21	26679-*	ACTUATOR CASE GASKET	2
22	26569-*	DIAPHRAGM RETAINING NUT	1
23	70152-*	HHCS 1/4-20 X 7/8	20
24	26575-*	DIAPHRAM RETAINER	1
25	27548-*	ADJUSTING SCREW	1

Key	Part Name	Description	Qty.
26	81660-*	5/16-18 JAM NUT	1
27	68160-*	SEAL WASHER- DIAPHRAGM RETAINER	1
28	26681-*	HHCS FOR LOWER CASE 1/4-20UNC X 3.5	4
29	SEE BE- LOW	O-RING 2-110	1
30	26578-*	PILOT PISTON	1
31	86351-*	PILOT BODY INNER O-RINGS 2-128	2
32	24265-*	PILOT UPPER CAGE O-RING 2-122	1
33	SEE BE- LOW	MAIN PLUG O-RING	1
34	SEE BE- LOW	PILOT BODY/ MAIN BODY O-RING	1
35	8328-*	LOCKWASHER 1/4 SPLIT	20
36	8418-*	HEX NUT 1/4-20	20
37	26904-*	3/4" NPT PLUG (TRUNCATED)	1
38	VARIABLES	RANGE SPRING	1
39	VARIABLES	MAIN RETURN SPRING	1
40	26828-*	RETURN SPRING - PILOT	1
41	8319-*	LOCK WASHER 10/32 SPLIT	1
42	26682-*	SCREW 10-32 x 5/8	1
43	86233-*	1/4" THREADSEAL WASHERS	4
44	7947-*	HHCS FOR S/H 1/4-20 x 5/8	4
45	86356-*	#018 CLOSING CAP O-RING	1

Mark 908 Series Tank Blanketing Valve

Mark 908 Flow Charts													
CAPACITIES IN SCFH & Nm ³ /h OF NITROGEN				Cv 1		Cv 2		Cv 4		Cv 7.5		Cv 10	
psig	bar	kg/cm ³	kPa	SCFH	Nm ³ /h	SCFH	Nm ³ /h	SCFH	Nm ³ /h	SCFH	Nm ³ /h	SCFH	Nm ³ /h
25	1.7	1.76	172	1,404	39.8	3,120	88.4	5,024	142	9,256	262	11,001	312
30	2.1	2.11	207	1,584	44.9	3,521	99.7	5,670	161	10,446	296	12,416	352
40	2.8	2.81	276	1,940	55.0	4,312	122	6,944	197	12,791	362	15,203	431
50	3.4	3.52	345	2,276	64.4	5,057	143	8,278	234	15,540	440	20,144	570
60	4.1	4.22	414	2,628	74.4	5,839	165	9,558	271	17,943	508	23,258	659
70	4.8	4.92	483	2,979	84.4	6,621	188	10,837	307	20,345	576	26,372	747
80	5.5	5.62	552	3,304	93.6	7,342	208	11,537	327	22,747	644	29,486	835
90	6.2	6.33	621	3,856	109	8,569	243	13,466	381	25,149	712	32,600	923
100	6.9	7.03	689	4,225	120	9,388	266	14,753	418	27,551	780	35,713	1011
110	7.6	7.73	758	4,593	130	10,206	289	16,039	454	29,953	848	38,827	1100
120	8.3	8.44	827	4,961	141	11,025	312	17,325	491	32,356	916	41,941	1188
130	9.0	9.14	896	5,329	151	11,843	335	18,611	527	34,758	984	45,055	1276
140	9.7	9.84	965	5,698	161	12,662	359	19,898	564	37,160	1052	48,168	1364
150	10.3	10.55	1034	6,066	172	13,480	382	21,184	600	39,562	1120	51,282	1452
160	11.0	11.25	1103	6,435	182	14,299	405	22,470	636	41,964	1188	54,396	1540
170	11.7	11.95	1172	6,803	193	15,118	428	23,756	673	44,366	1256	57,510	1629
180	12.4	12.66	1241	7,171	203	15,936	451	25,043	709	46,768	1324	60,624	1717
190	13.1	13.36	1310	7,540	214	16,755	475	26,329	746	49,171	1393	63,737	1805
200	13.8	14.06	1379	7,908	224	17,573	498	27,615	782	51,573	1461	66,851	1893

Conversion Factors:

Air- Multiply by 0.985

Dry CO₂- Multiply by 0.797

Natural Gas (sg 0.60)- Multiply by 1.270

For all other gasses, compute a correction factor which is equal to $0.985/(\sqrt{SG})$. Then multiply by the correction factor.